

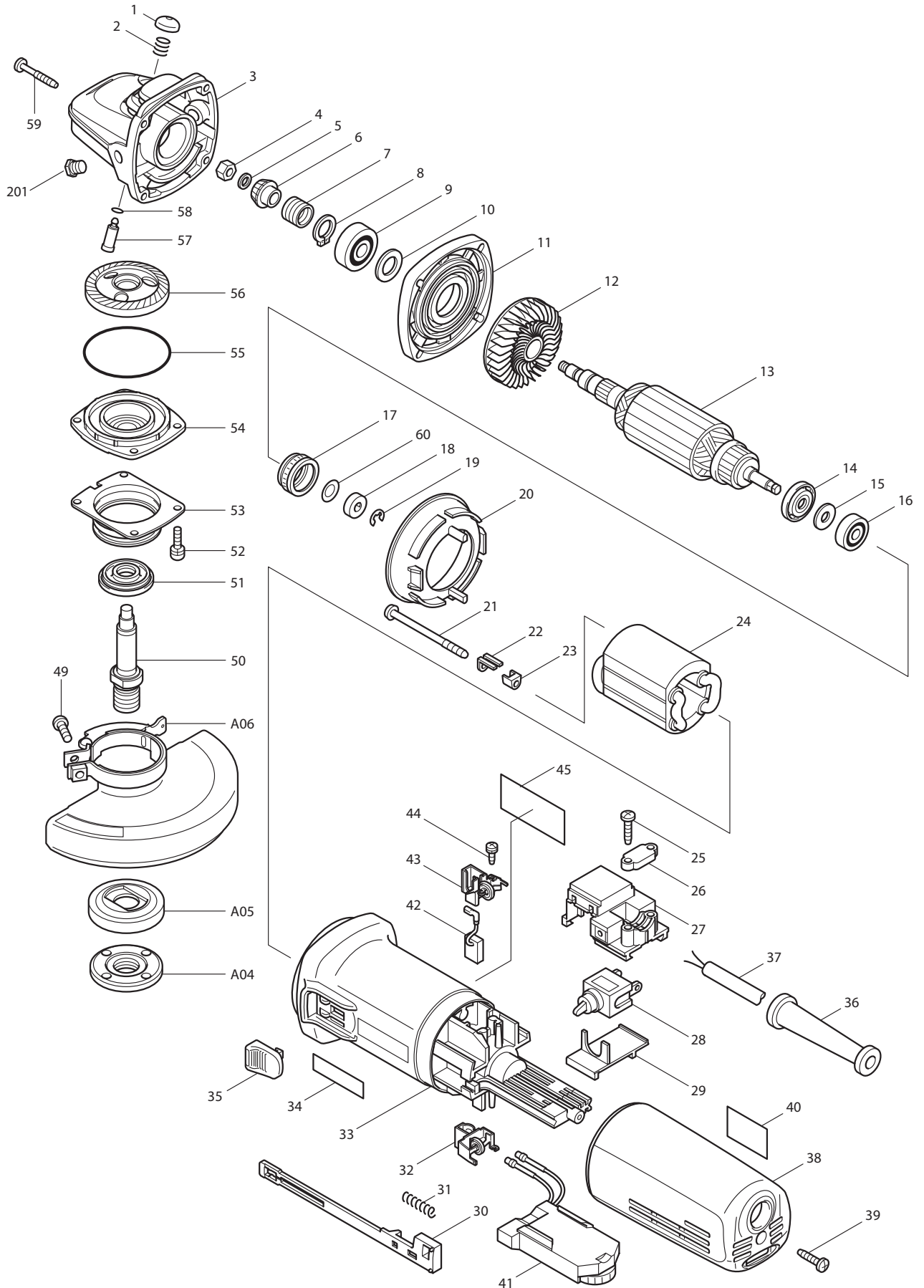

02 - 2013

9565CV

5" ANGLE GRINDER (5/8" - 11UNC)



Item No	Type	Ref	Part No	Description (*See Service Change)	Qty	Unit
001	2		418067-8	* PIN CAP	1	PC.
002			233072-2	COMPRESSION SPRING 8	1	PC.
003	4		153488-4	* GEAR HOUSING COMPLETE	1	PC.
		INC.	211021-9	* BALL BEARING 607LLB	1	PC.
004			931303-0	HEX. NUT M6	1	PC.
005			253077-6	FLAT WASHER 6	1	PC.
006	2		227513-8	* SPIRAL BEVEL GEAR 11	1	PC.
007			233901-9	LOCK SPRING 12	1	PC.
008			961052-5	RETAINING RING S-12	1	PC.
009			211142-7	BALL BEARING 6001LLB	1	PC.
010			253084-9	FLAT WASHER 12	1	PC.
011			317359-1	GEAR HOUSING COVER	1	PC.
012			240033-5	FAN 57	1	PC.
013	4		518160-9	* ARMATURE ASS'Y 115V	1	PC.
		INC.		* Item No. 12,14-16		
014			681656-4	INSULATION WASHER	1	PC.
015			253823-7	FLAT WASHER 7	1	PC.
016			210027-4	BALL BEARING 627DDW	1	PC.
017	1		421738-8	LABYRINTH RUBBER RING 22	1	PC.
	2		422750-1	LABYRINTH RUBBER RING 22	1	PC.
018			688117-5	MAGNET SLEEVE	1	PC.
	2		259039-2	* SELF LOCK 6	1	PC.
020			413076-2	BAFFLE PLATE	1	PC.
021			266258-3	TAPPING SCREW 4X70	2	PC.
022			344871-8	RETAINER	2	PC.
023			417237-6	INSULATION COVER	2	PC.
024			626501-6	FIELD 115V	1	PC.
025	2		265A48-7	TAPPING SCREW 4X18	2	PC.
026			687063-9	CORD CLAMP (STRAIN RELIEF)	1	PC.
027			632999-7	SWITCH BLOCK	1	PC.
028			651418-4	SWITCH ST115A-40	1	PC.
029			687113-0	COVER	1	PC.
030	1		417186-7	* SWITCH LEVER	1	PC.
	2		453847-5	* SWITCH LEVER	1	PC.
031			233071-4	COMPRESSION SPRING 4	1	PC.
032	3		644003-0	BRUSH HOLDER	1	PC.
033	5		153775-1	* MOTOR HOUSING COMPLETE	1	PC.
		INC.	810341-4	* CAUTION LABEL	1	PC.
	6		144228-1	* MOTOR HOUSING COMPLETE	1	PC.
		INC.	810341-4	* CAUTION LABEL	1	PC.
034			819080-3	MAKITA LABEL (OLD)	1	PC.
035	2		417813-6	* SWITCH KNOB (OLD# 417188-3 - N/L/A)	1	PC.
036			682566-8	CORD GUARD 10	1	PC.
037			664265-4	CORD WITH PLUG 2P-16-2.5M SJ	1	PC.
038	4		140090-2	* REAR COVER COMPLETE	1	PC.
		INC.	810523-8	* CAUTION LABEL	1	PC.
	5		144229-9	* REAR COVER COMPLETE	1	PC.
		INC.	810315-5	* CAUTION LABEL	1	PC.
039	2		265A48-7	TAPPING SCREW 4X18	1	PC.
040	2		816795-3	INDICATION LABEL	1	PC.
041			631383-3	CONTROLLER	1	PC.
042	5		196454-8	A.C. CARBON BRUSH CB-340 2PC/SET (W/ ORIGIN)	1	SET
043	3		644003-0	BRUSH HOLDER	1	PC.
044			266256-7	TAPPING SCREW PT3X10	4	PC.
045			852401-6	NAME PLATE 9565CV	1	PC.
049	1		251391-4	* PAN HEAD SCREW M5X16	1	PC.
	2		265180-1	* PAN HEAD SCREW M5X16	1	PC.
050			324038-4	* SPINDLE	1	PC.
051			415300-9	LABYRINTH RING	1	PC.
052	1		266260-6	HEX. SOCKET HEAD BOLT M4X16 - M/L/A	4	PC.
	2		265490-6	HEX. SOCKET HEAD BOLT M4X16	4	PC.
054	3		318302-3	* BEARING BOX	1	PC.
	4		318334-0	* BEARING BOX	1	PC.

Item No	Type	Ref	Part No	Description (*See Service Change)	Qty	Unit
055			213673-2	O RING 52	1	PC.
056	2		227514-6	* SPIRAL BEVEL GEAR 38	1	PC.
057			256459-1	PIN	1	PC.
058			213048-5	O RING 6	1	PC.
059			266257-5	TAPPING SCREW 4X28	4	PC.
060			267756-0	WAVE WASHER 6	1	PC.
063			285841-7	* BEARING RETAINER (Added)	1	PC.
064			211129-9	* BALL BEARING 6201DDW (Added)	1	PC.
100			654037-5	INSULATED EYE TERMINAL FT1.25-M3	2	PC.
101			652037-9	P.H. SCREW M3.5X8	2	PC.
200			265083-9	(+) FLAT HEAD SCREW M8X11 (F/ HEAD COVER)	1	PC.
201			265083-9	(+) FLAT HEAD SCREW M8X11 (F/ GEAR HOUSING COM.)	1	PC.

ACCESSORIES

-See catalogue or visit www.makita.ca for more optional accessories-

A02	1		D-18465	5" GRINDING WHEEL 125X6X22 A24R-BF	1	PC.
	2		D-20797	5" ABRASIVE DEPRESSED CENTRE WHEEL A24R	1	PC.
	Opt.		-----	DEPRESSED CENTER GRINDING WHEELS		
A03			782412-6	LOCK NUT WRENCH 28	1	PC.
A04	2		224568-4	* LOCK NUT 5/8-45	1	PC.
A05	3		224399-1	* INNER FLANGE 45	1	PC.
		INC.	213009-5	* O RING 4 (Added)	1	PC.
A06	3		135650-3	* TOOLLESS WHEEL COVER ASSY F/5"	1	PC.
		INC.		* Item No. 49		
	4		123145-8	* TOOLLESS WHEEL COVER ASSY F/5"	1	PC.
		INC.		* Item No. 49		
A07			417322-5	HEAD COVER	1	PC.
A08	1		195236-5	#195236-5	1	PC.
	2		196575-6	#196575-6	1	PC.
A09	1		196846-1	DUST COLLECTION COVER 5" DMND, TUCKPOINT BLADE	1	PC.
	2		196845-3	DUST COLLECTION COVER 5" DMND, TUCKPOINT BLADE	1	PC.
A10			-----	4-1/2" - 5" DIAMOND TUCKPOINT BLADES		
A11	1		122641-3	CUT-OFF WHEEL GUARD F/5"	1	PC.
	2		122911-0	CUT-OFF WHEEL GUARD F/5"	1	PC.
A12			-----	DIAMOND CUP WHEELS (Use with Item No. A08)		

SERVICE CHANGES

1. Changes on Gear Housing Complete and Pin Cap.

Item No.	Description	(T/I# 64723)		(T/I# 69773)	(T/I# 76564)
		Type1	Type2	Type3	Type4
1	Pin Cap		417236-8		418067-8
3	Gear Housing Com.	151991-9(N/L/A)	153381-2(N/L/A)	153718-3(N/L/A)	153488-4

Above parts are completely interchangeable as a set.

Item 3

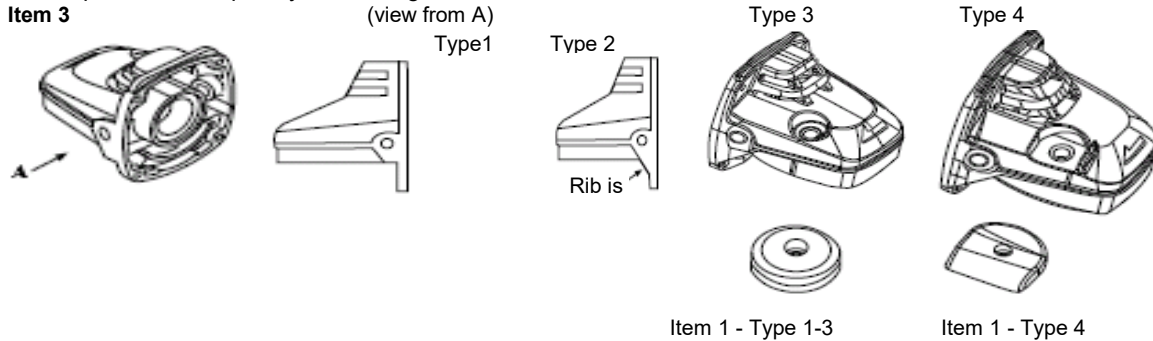

2. Changes on Spiral Bevel Gear 11 and 38

Item No.	Description	(T/I# Z8388A)	
		Type 1	Type 2
6	Spiral Bevel Gear 11	226794-1	227513-8
56	Spiral Bevel Gear 38	226795-9	227514-6

Above parts are completely interchangeable as a set.

3. Changes on Armature Assy and Stop Ring / Self Lock

Item No.	Description	(T/I# 66600)		(T/I# 84800)
		Type1	Type2	Type3
13	Armature Assy	515166-8	515226-6	515336-9
19	Stop Ring / Self Lock	961011-9	259039-2	

Above parts are completely interchangeable as a set.

Type1

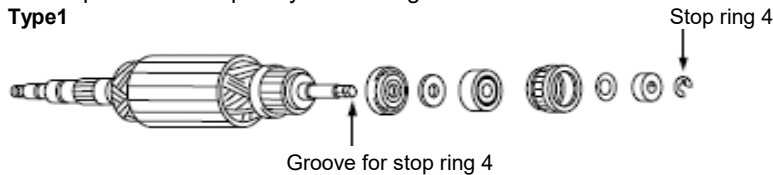

Type2-

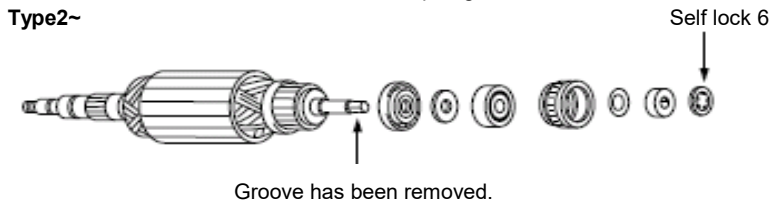

4. Changes on Motor Housing and Switch Knob

Item No.	Description	(T/I# 64723)		(T/I# 69773)	(T/I# 76564)
		Type1	Type2	Type3	Type4
33	Motor Housing	417182-5(N/L/A)	153294-7(N/L/A) (W/ Label)	153771-9(N/L/A) (W/ Label)	418512-3 (W/O Label)
35	Switch Knob	417188-3	417813-6		
38	Rear Cover		417185-9 (W/O Label)		158190-4 (W/ Label)
Item No.	Description	Type5	Type6	Type7	
30	Switch Lever		417186-7	453847-5	
33	Motor Housing		153775-1	144228-1	
38	Rear Cover Complete	158314-2	140090-2	144229-9	

Type 1 - 4 are completely interchangeable as a set.

(T/I#B3430)

Type7 Item no. 30 & 33 are completely interchangeable as a set.

SERVICE CHANGES

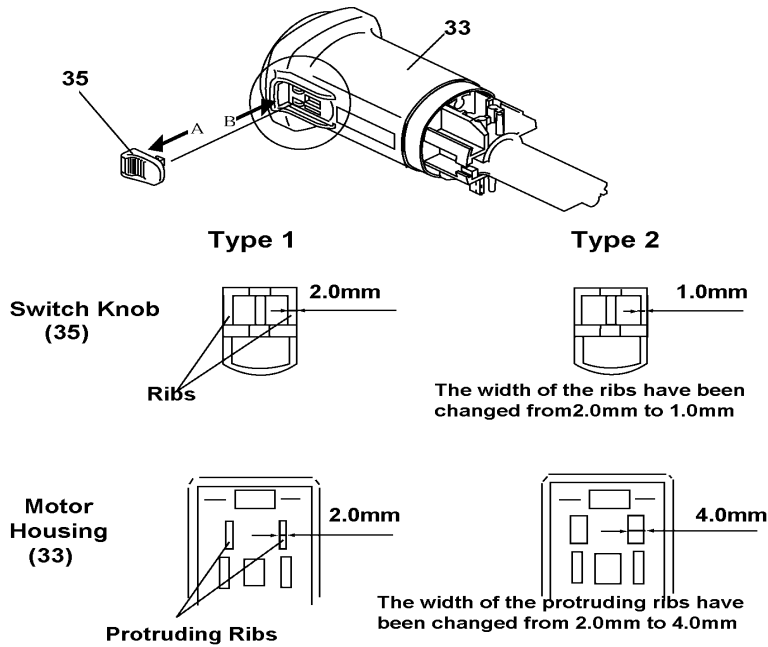

5. Changes on Bearing Box Complete and Wheel Cover Assy

Item No.	Description	(T/I# 64438)		(T/I# 80668)	(TI#B3430)
		Type1	Type2	Type3	Type4
49	Pan Head Screw M5X16	251391-4			265180-1
53	Wheel Cover Base	344872-6	-----		
54	Bearing Box	151927-8 (complete)	317570-5	318302-3	318334-0
63	Bearing Retainer	-----	285841-7		
64	Ball Bearing 6201DDW	-----	211129-9		
A06	Toolless Wheel Cover Assy	163415-3	135108-2(TI#76633)	135650-3(TI#A462)	123145-8
A06 Inc.	O ring 4	-----			213009-5
A08 Opt.	Dust Collection Cover	195236-5			196575-6
A09 Opt.	Dusct Collection Cover F/Diamond & Tuckpoint Blade	196846-1			196845-3
A11 Opt.	Cut-Off Wheel Guard	122641-3			122911-0

Type 1 - 3 Item no. 53,54,63,64 parts are completely interchangeable as a set.
 Type 3 - 4 parts are completely interchangeable as a set.

Bearing Box Type 1 --> Type2

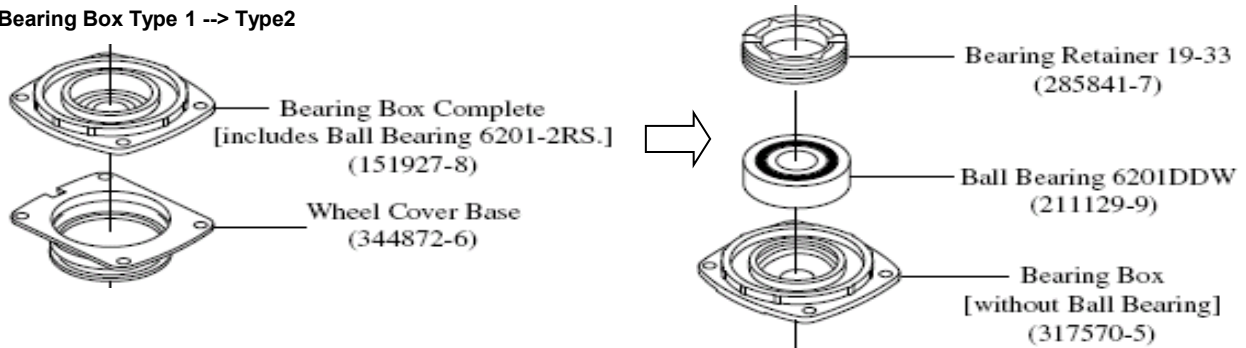

Bearing Box Type 2 --> Type3

Bearing Box Type 3 --> Type4

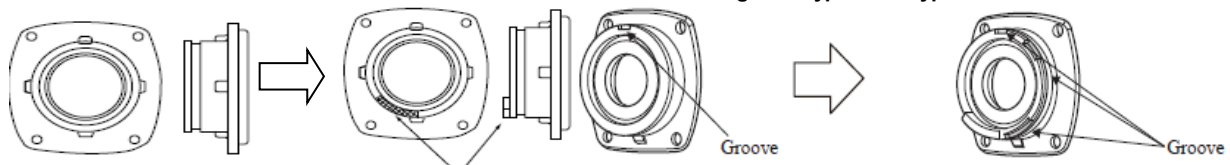

Toolless wheel cover Type 2 --> Type3

SERVICE CHANGES

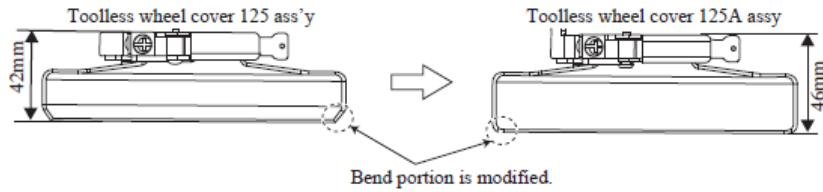

Toolless wheel cover Type 3 --> Type4

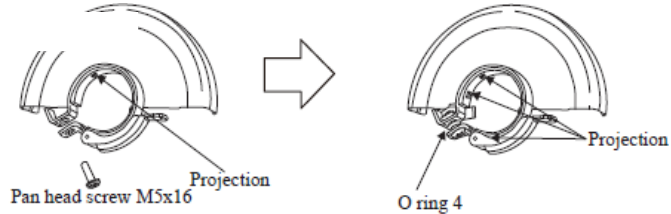

5. Changes on Inner Flange and Lock Nut

Item No.	Description	(T/I# 64669)		(T/I# 80501)
		Type1	Type2	Type3
A04	Lock Nut	224566-8		224568-4
A05	Inner Flange	224368-2	224378-9	224399-1

Above parts are completely interchangeable as a set.

6. Changes on Spindle

Item No.	Description	(T/I# 65732)	
		Type1	Type2
50	Spindle		324038-4

End of Spindle has been changed in dimensions.

Use an arbor press to insert a new Spindle into Gear Housing Complete as it is too tight to be inserted by hand. To distinguish the new Spindle from current one, a line has been added on it as shown below. Part No. remains the same.

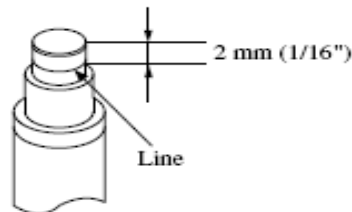

Note:

When removing or installing Gear Assembly (assembled part of Spiral Bevel Gear, O Ring, Bearing Box Complete, Wheel Cover Base, Hex. Socket Head Bolt, Labyrinth Ring and Spindle), do as follows.

<Removing>

If you have difficulty removing the Gear Assembly from machine body, use a plastic hammer to strike the shaded portion of the machine.

Strike this shaded portion with a plastic hammer.

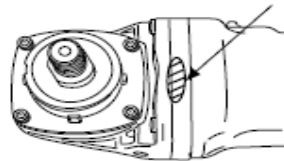

<Installing>

When installing the Gear Assembly on machine body, use a plastic hammer to strike the shaded portion of the machine.

Strike this shaded portion with a plastic hammer.

